

Texas Boom Company Specifications – 18 Inch Permanent Boom

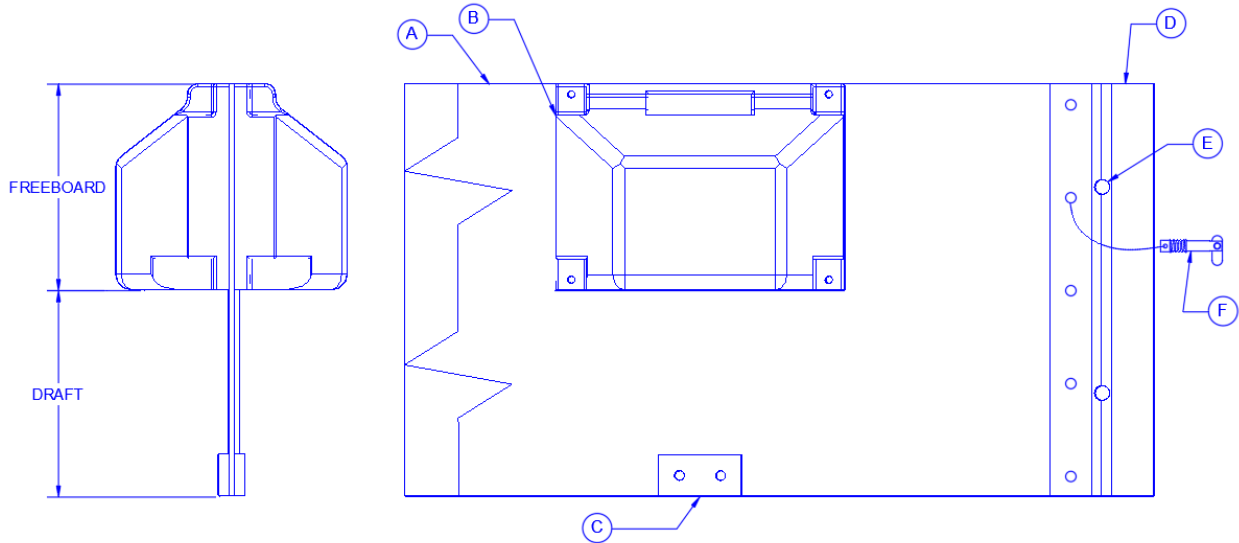

18 Inch Permanent Containment Boom
TXB-PB-18
Diagram Illustrative Only – Not to Scale
Freeboard: 10 inches
Draft: 8 inches
Section length: 50 feet
Floats per 50' section: 20
Fabric: 150 oz PVC Conveyor Belt w/ UV protection and marine growth inhibitor
Color: Black belt with orange floats
Floatation: Polyethylene (PE) shells with UVEXTM antioxidant and UV protection filled with oil impervious closed-cell foam
Ballast: Galvanized steel plates
End connectors: ASTM F962-94 universal "Z" connector, fitted with stainless steel toggle pin and lanyard
Anchor points: 2
Weight per 50' section: 200 pounds
Barrier ultimate tensile strength: 27,000 pounds
Buoyancy to weight ratio: 4:1
Section length options: 25 ft / 50 ft

Boom Configuration
A: Belt
B: Foam Filled Polyethylene Float
C: Ballast Plate
D: ASTM End Connectors
E: Toggle Pin hole
F: Toggle Pin



Texas Boom Company
16600 Park Row Drive
Houston, TX 77084
(281) 441-2002
sales@texasboom.com
www.TexasBoom.com